

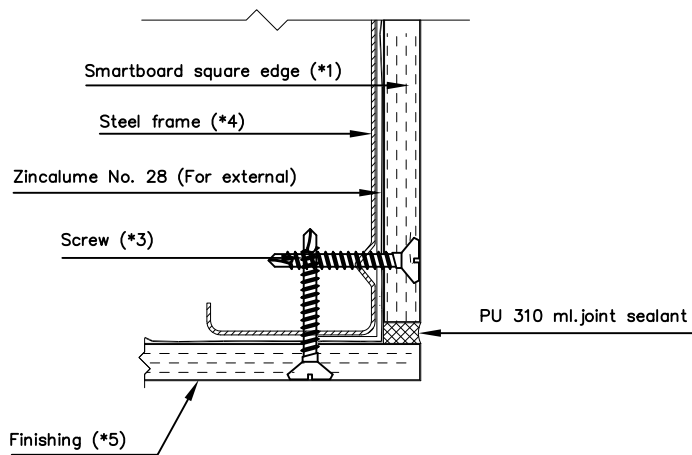

No space lining installation



Space lining installation

* Note

- *1 SCG Smartborad 8, 10, 12mm. thick, choosing appropriate work
- *2 SCG self drilling wing screw 32 mm.
- *3 For SCG Smartboard 3.5–8 mm. thick, using SCG Needle point screw 23 mm. fix on steel frame 0.55–0.80 mm. thick.
For SCG Smartboard 6–12 mm. thick, using SCG self drilling wing screw 32 mm. fix on steel frame 1.2–3.2 mm. thick.
- *4 For No Space lining solution, using steel frame thickness at least 0.55 mm., width at least 38 mm.
For space lining solution, using steel frame thickness at least 0.55 mm., width at least 42 mm.
If steel frame thickness size is less than aforementioned size, should add frame more (Double frame)
- *5 Painting by Acrylic paint 100% for external or covering by other decorative material such as wall paper

DIMENSIONS...MM.	NAME	DATE		SCALE : NOT TO SCALE	PAGE : 10/13	
DRAWN : .RATHACHART Y.		22/04/2557		installation outside corner		
DESIGNED : .DEJA W.		-				
CHECKED : .DEJA W.		-				
APPROVED : .BODIN D.		-				
CANCEL DWG.NO. : .			DIR/FILE :			
REFER DWG.NO. : .						
CEMENT-BUILDING MATERIALS CO.,LTD.			SCG Smartboard		